

T. WIDDOWSON,
Umbrella-Runner.

No. 211,361.

Patented Jan. 14, 1879.

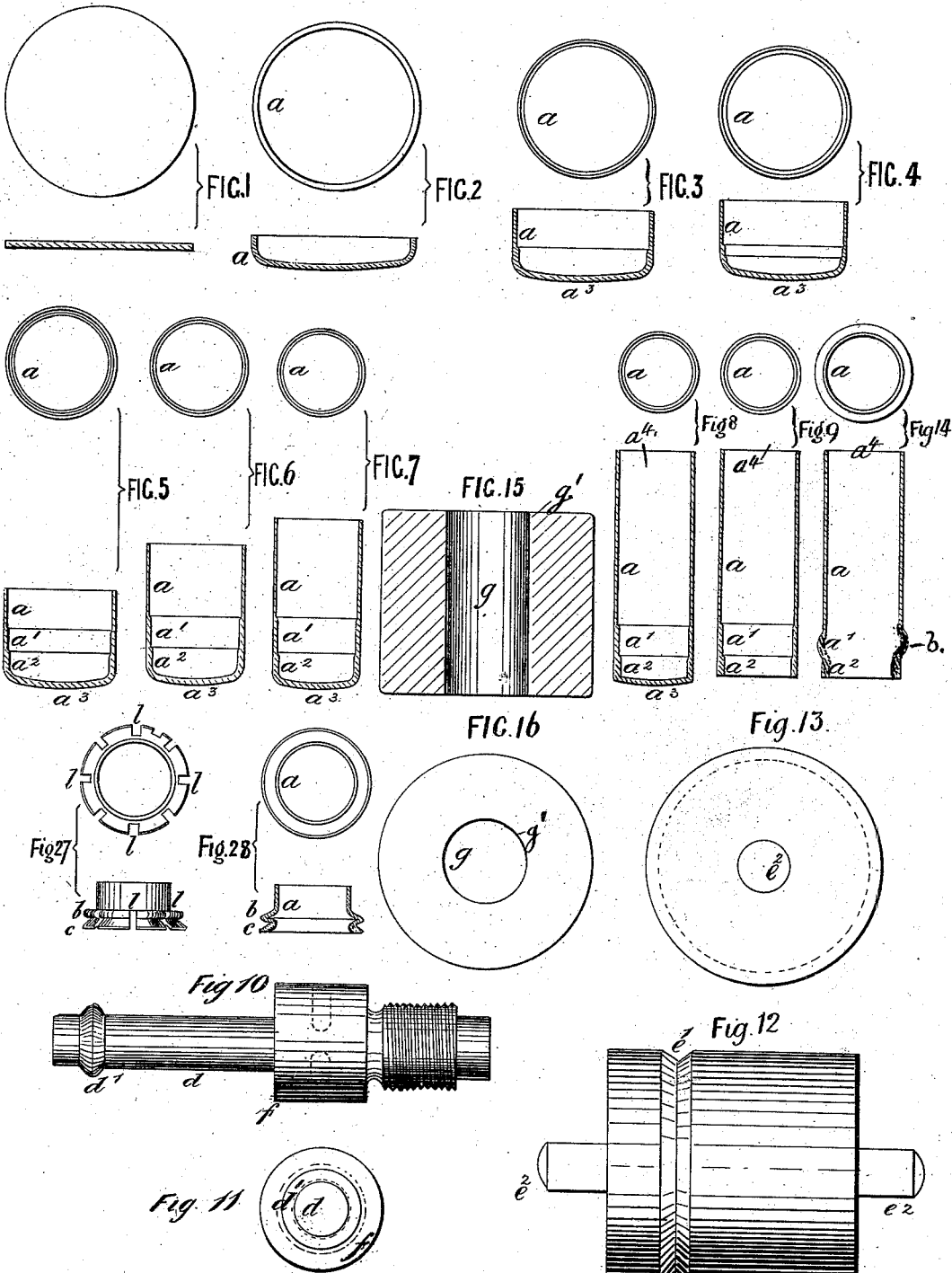

Witnesses:
Penn Halsted
Geo Bacon

Inventor:
Thomas Widdowson
by John Halsted
Atty.

T. WIDDOWSON. Umbrella-Runner.

No. 211,361.

Patented Jan. 14, 1879.

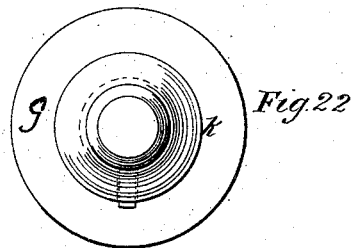
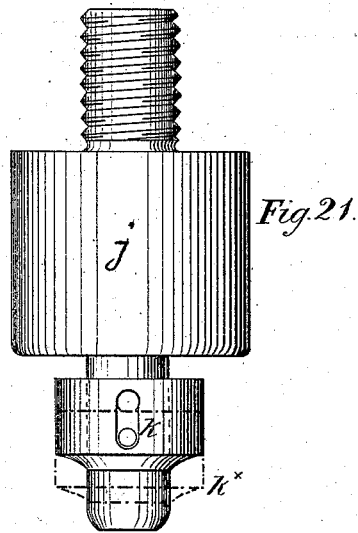
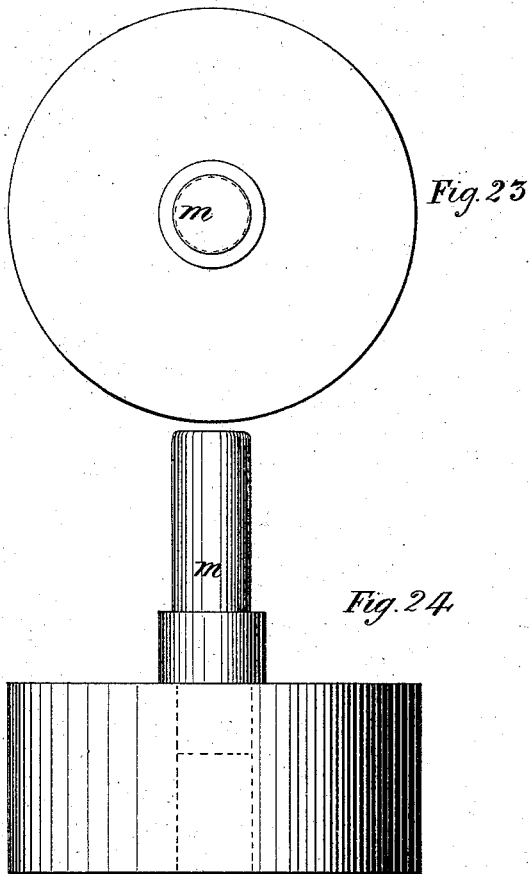
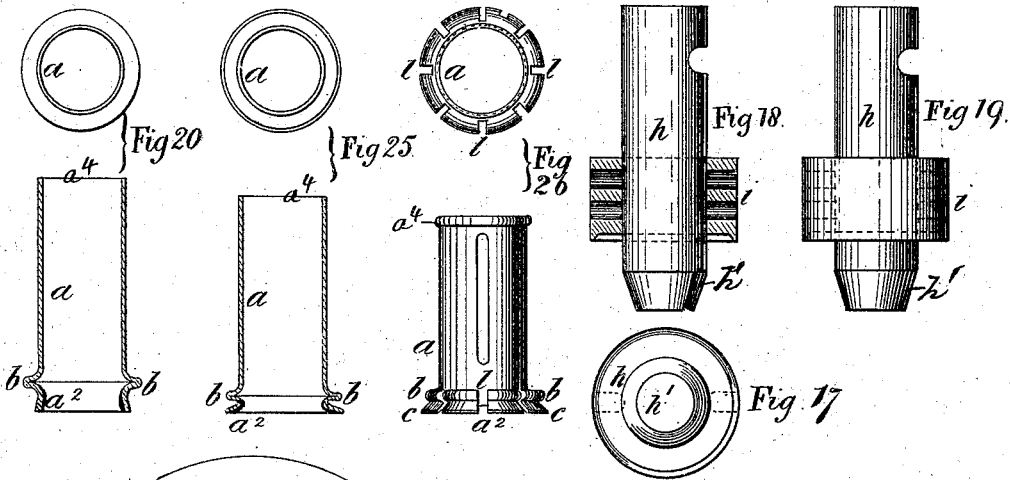

Witnesses:
Jenn Walsted
Levi Bacon

Inventor:
Thomas Widdowson
by John H. ...

UNITED STATES PATENT OFFICE.

THOMAS WIDDOWSON, OF SHEFFIELD, ENGLAND.

IMPROVEMENT IN UMBRELLA-RUNNERS.

Specification forming part of Letters Patent No. **211,361**, dated January 14, 1879; application filed May 24, 1878; patented in England, February 19, 1878.

To all whom it may concern:

Be it known that I, THOMAS WIDDOWSON, (of the firm of Thomas Widdowson & Co.,) of Sheffield, England, manufacturer, have invented new and useful Improvements in Top Notches and Runners for Umbrellas, Parasols, and Sun-Shades, which improvements are fully set forth in the following specification, reference being had to the accompanying drawings, and for which Letters Patent were granted in Great Britain, No. 3,971 for 1877, sealed February 19, 1878.

The object of the invention is greater strength and durability in the construction of the parts.

In carrying the invention into effect, I take a disk of metal, of size sufficient to produce the intended top notch or runner, as the case may be, and then, by means of dies and pressure, I force this disk into a tubular form to the extent desired for the tubular portion of the part. I then cut off the blank end thereof, and by the aid of a spindle with a bead or projecting rim thereon, aided by a grooved roller, I raise a projecting rim on this tube, toward one end thereof, to form one side of the intended notch. I then obtain the other side of the notch by a punch and die, so as to form two sides or a pair of projecting rings, leaving a space or groove all round between these sides or rings to receive the wire, by which the ends of the ribs or stretchers are afterward to be held thereto.

The openings to receive the ends of the ribs or stretchers are then cut by a saw or otherwise, as desired. The end of the tube opposite the notches for runners I turn over to form a bead, in the usual way; but that the invention may be the better understood, I will, by the aid of the accompanying drawings, proceed to describe means pursued by me in carrying the same into effect.

Referring to the drawings, Figure 1 shows, by plan and section, a disk of metal of size adapted to produce a runner, *a*. Figs. 2, 3, 4, 5, 6, 7, and 8 show, by sectional and plan views, respectively, the progressive forms of the disk of metal, Fig. 1, obtained by successive operations of dies and pressure, as is well understood.

The dies used during these successive stages being in the main of the character of those or-

dinarily employed for corresponding purposes, I have not thought it necessary to show them. I would, however, remark that in operating on the metal during these successive stages for the purpose of my invention the internal punches or upper dies are formed to admit of the metal being left thicker at the parts *a*¹ *a*² than at the upper parts, *a*, thereof, so as to admit of greater strength being given to the projecting rims which are to be formed therefrom than would be the case if those parts were reduced by the punches or dies to the same thickness as the remainder of the tube.

Having produced, by successive punching operations, the tubular form represented by Fig. 8, I then cut off the blank end *a*³ thereof, when a tubular form of the character of that shown by the plan and section, Fig. 9, will be produced. This tubular form is then placed over a spindle, *d*, of the character of that represented by side view, Fig. 10, and end view, Fig. 11, and which spindle is applied, by screwing or otherwise, into the shaft of a lathe or other suitable shaft by which quick rotary motion may be given to it. The spindle *d* is formed with a bead or projecting rim, *d*¹, thereto; and when a tube, *a*, Fig. 9, has been applied on the spindle *d*, and the spindle *d* has been set in rotary motion, a roller, *e*, (shown by side view, Fig. 12, and end view, Fig. 13,) carried by its spindle *e*² in the fork of a lever-arm, is caused to bear with pressure on the tube *a* as that tube is carried round by the spindle *d*, when the action of the groove *e*¹, formed around the roller *e*, bearing with force on the external surface of the tube *a*, together with the internal pressure of the bead or rim *d*¹, will produce a projecting rim, *b*, on the tube *a* of the character of that represented by Fig. 14, and, if desired, a succession of spindles, *d*, and rollers *e*, with variations in form or extent of bead or rim *d*¹ and groove *e*¹, may be employed. In all cases the diameter of the bead or rim *d*¹ will have to be somewhat smaller than the interior of the body of the tube to be operated upon. *f* is an enlargement acting as a stop on the spindle *d*, adapted to the length of tube *a* for the time under operation. The rollers *e* may also be variable in width to correspond.

A tube, *a*, produced to a form somewhat as

represented by Fig. 14, by the means thus described or by other suitable means, is then placed with its longer end, a , in a bottom die, g , (shown by section, Fig. 15, and by plan view, Fig. 16,) and with its projection b resting on the upper edge, g' , of the bore thereof, when the end a^2 of the tube a will first be operated upon by the conical end h' of a punch, h , (shown by end view, sectional view, and side views, Figs. 17, 18, and 19,) so as to produce a somewhat open or bell mouth to that end a^2 , and by the collar i to compress the part b , as indicated by Fig. 20, and by the use of another upper die, j , provided with a collar, k , capable of movement as indicated by the dotted lines k^* , to release the tube a when acted upon as desired, and represented by side view and plan, Figs. 21 and 22, in connection with the bottom die, Fig. 15, and by the internal support, m , formed to the base or supporting block shown by plan and side views, Figs. 23 and 24. The end a^2 of the tube a is further acted upon so as to turn down the end a^2 , and thereby to form a rim, c , which, with the bead or projection b , forms a pair of rims, as represented by Fig. 25, with a space between them for the wire, as is well understood.

The rim c , it will be observed, is a single thickness of metal, while the bead b is of a double thickness or corrugation. The material from which the flaring or bell-shaped rim c is formed is greater, however, in thickness than that from which the bead b is formed, in order that this outer part, which is unsupported and not strengthened by corrugation, shall have sufficient rigidity and strength to meet all the demands to be made upon it when in use.

The several portions a , a^1 , and a^2 of the tube, while of different relative thicknesses, are each severally uniform in their thickness, as distinguished from a gradually tapering or di-

minishing thickness, such as is sometimes the case in the manufacture of cartridges, but which would not be desirable or practicable in umbrella top notches or runners. The collar k is acted upon by a lever or otherwise to give motion to it and push the runner or notch from the part j . The openings l , Fig. 26, in these rims b c , to receive the ends of the ribs or stretchers, are then cut by a saw or otherwise, as desired.

The end a^4 of the tube a , opposite that for the notches, I turn over to form a bead in the usual way. The top notches (represented by Figs. 27 and 28) are similarly produced.

In operating on the metal to produce the successive results referred to it will be understood that the metal will be annealed, as usual, when required.

Have thus described my invention, and means which I adopt in carrying the same into effect, what I claim is—

1. A tube for top notches or runners of umbrellas and parasols, having the metal at the part a^1 thicker than the part a , and that at a^2 thicker than the part a^1 , substantially as shown and described, and for the purposes set forth.

2. The improved top notch or runner described, having the metal of the beaded part b of greater thickness than that of the part a , and doubled or corrugated, and that of the part c of still greater thickness, and turned outward to form a rim, substantially as shown and described.

In testimony whereof I have signed my name to this specification in the presence of two subscribing witnesses.

THOMAS WIDDOWSON.

Witnesses:

W. E. TATTERSHALL,
Notary Public, Sheffield.

J. S. C. HORRY,
Sheffield, Clerk to Mr. W. E. Tattershall.